

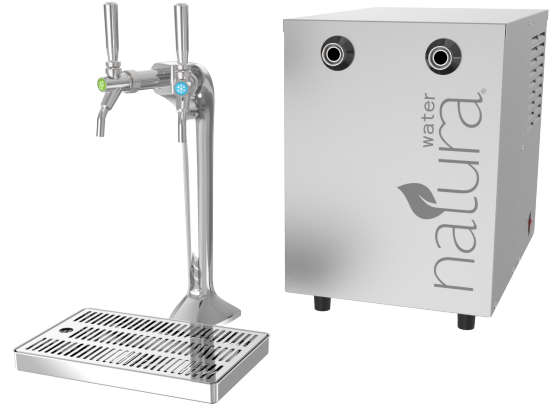

# NATURA 2 TAP DISPENSING TOWER WITH REMOTE CHILLER 1.35 Water Purification System Specifications



## TECHNICAL MODEL NWSBU2 - SERIES 4

TYPE OF MACHINE	2 Tap Dispensing Tower w/ Remote Chiller
MOST COMMON USE	Restaurant, Hospitality & Corporate Office
WATER FILTRATION SYSTEM	3-Stage Filtration - Sediment, Chlorine, Taste, Odor (CTO), Lead & Cysts
CONFIGURATION OF MACHINE	Consists of 1 filtration assembly (NWFS) + 1 refrigeration/carbonation unit (NWSB) + 2 Tap Tower
CO2 CYLINDER (not provided by Natura)	Sold separately - connected with a 1/4" JG tubing and pressure regulator (included) to the refrigeration/ carbonation unit (NWSB)
MATERIAL	Galvanized Steel Body
MAXIMUM CHILL CAPACITY	35 Liters per hour
MAXIMUM FLOW CAPACITY	150 Liters per hour
AVG. TIME TO FILL A ONE LITER BOTTLE	15 Sec.
STANDARD OPER'G WATER SUPPLY PRESSURE PSI (BAR)-REGULATED WITH A PRESSURE REGULATOR (INCLUDED)	40 psi min. - 100 psi max. (2.75 - 6.9 bar)
ELECTRIC POWER CONSUMPTION (APPROXIMATE)	165 Watts Normal Oper'g/6 Watts Idle 285 Watts Carbonation Oper'g
ELECTRICAL (VOLTS/HERTZ/AMPS)	110-120V / 60HZ / 5 AMPS
REFRIGERATION GAS	R134a

## Standard Features

- Delivers Chilled Sparkling and Still Water
- 3-Step Advanced Filtration Process
- Eco-Friendly Alternative

	Refrigeration/ Carbonation (NWSB)	Filtration System (NWFS)	2 Tap Tower w/ Taps
DEPTH	19.1" (485.1 mm)	6.0" (152.4 mm)	8.5" (215.9 mm)
WIDTH	12.6" (320 mm)	16.4" (416.6 mm)	5.5" (139.7 mm)
HEIGHT	17.84" (453.1 mm)	14.4" (365.8 mm)	18.75" (476.25 mm)
WEIGHT	55 lbs (25 kg)	18 lbs (8.2 kg)	11.2 lbs (5.1 kg)





## Refrigeration/Carbonation Unit 2 Tap Dispensing Tower

### 2 TAP TOWER

### REMOTE CHILLER UNIT NWSBU2 - SERIES 4

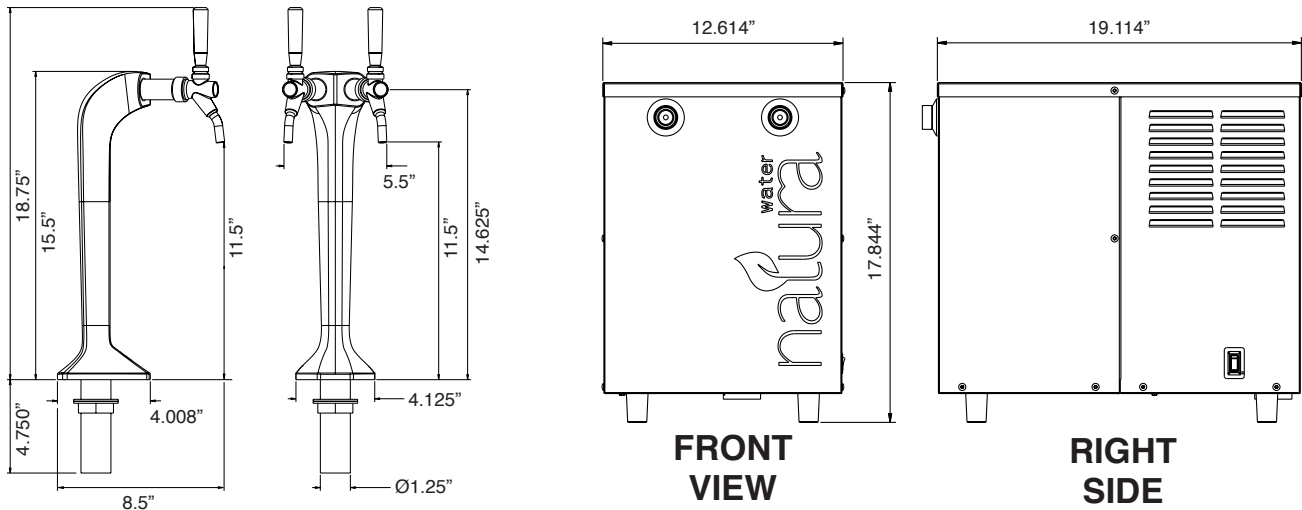

### Natura Water Installation Layout

